

Section 5: ZEVAC® for Main Repairs



Problem Description

In the context of pipeline maintenance, a main repair project often involves the isolation of a specific section of pipeline that is then depressurized and cut to carry out necessary repairs. Traditionally, this isolation process has relied on the closure of valves, pressure control fittings (PCFs), and other conventional pipeline isolation devices that allow the section of pipeline to be safely separated from the rest of the system. However, a significant challenge arises during this isolation process: the natural gas trapped in the intermediate pipe needs to be vented into the atmosphere. This venting can result in increased costs arising from various factors that include loss of product, the need to alert local fire departments, the dispatching of crews to address odor complaints, and the overall reporting of emissions to regulators.

The primary objective of implementing ZEVAC is to eliminate the need for venting during isolation and repair activities. ZEVAC enables the transfer of the gas from the section being depressurized back into the live side of the pipeline or an adjacent pipeline if available. This approach reduces emissions and also minimizes the release of natural gas into the surrounding environment. When using ZEVAC, one crucial aspect to consider when conducting main repair projects is the location of drawdown and discharge points.

ZEVAC is designed to effectively drawdown pipelines of varying lengths and diameters, making it a versatile solution for different repair scenarios. By utilizing ZEVAC, repair teams can carry out their work with minimal disruption and reduced visibility.

An additional advantage ZEVAC presents over typical depressurization methods is its low visibility during use. The importance of minimizing attention during main repair projects in populated areas cannot be overstated, as the public will often be quick to notice changes to their surroundings. Often, when main repair projects take place in a populated area, traditional methods of flaring and gas blowdown would draw attention and create concerns for both public safety and the safety of the workers involved. By utilizing ZEVAC, the visibility and attention to the repair project can be minimized, mitigating potential risks and ensuring the well-being of both the public and the workers.

In summary, main repair projects in pipeline maintenance involve isolating specific pipeline sections for repair purposes. ZEVAC addresses the challenge of gas venting during the isolation process by transferring the captured gas back into the pipeline, reducing emissions and environmental impact. ZEVAC can handle pipelines of various lengths and diameters, providing flexibility for different repair scenarios. Minimizing attention and visibility is crucial in populated areas to ensure public and worker safety, and ZEVAC is invaluable in achieving this objective.

Illustrated Checklist and Diagram

Prior to ZEVAC use, it is essential to identify the procedural steps that will need to take place to have an impactful main repair. The major procedural steps for a main repair include:

1. Recognizing and understanding Maximum Allowable Operating Pressure (MAOP) of pipeline and flow of gas. Example: Looped systems or dead-end systems.
2. Identification of isolation valves for intake and discharge points.
3. Utilize stopple or close valves to stop the flow into the portion of the pipe to be depressurized.
4. Connect the ZEVAC unit to the installed taps using flex hoses and appropriate fittings. Then, connect the ZEVAC unit to the air compressor with the air hose. Ensure the whip checks are in place and open the tap valves. Purge air from the ZEVAC hoses and equipment before starting actual recompression.

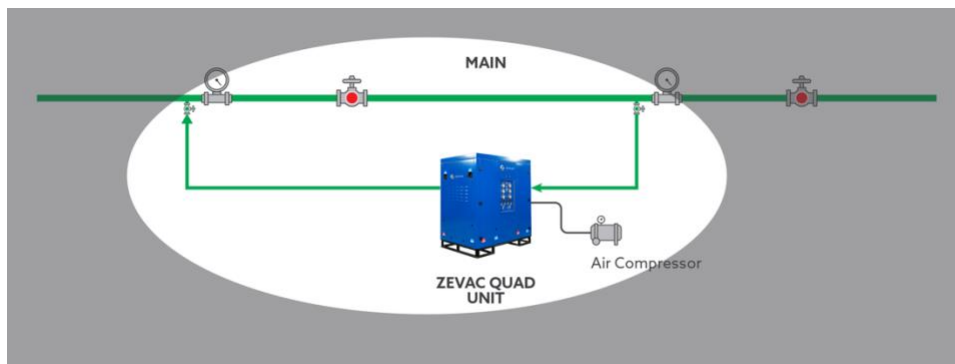

Figure 29: Diagram of main repair drawdown (Image 1 of 4)

5. Record starting pressure of both the discharge portion of the pipe and the intake segment.
6. Turn on the ZEVAC unit. Then turn on the air compressor to begin drawdown.
7. Monitor pressure at the discharge point and intake section to ensure discharge does not cause over-pressurization of the discharge side pipe system and intake does not go below the desired pressure. **Note:** The Under Pressure Cut Off Switch (UPCO) and Over Pressure Cut Off Switch (OPCO) are designed to ensure the unit shuts off before reaching MAOP or desired draw down pressure.

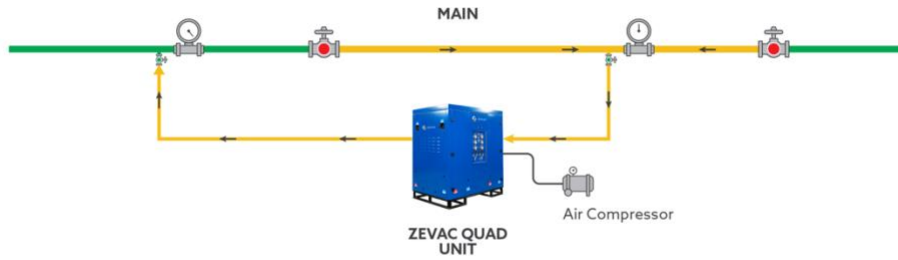

Figure 30: Diagram of main repair drawdown (Image 2 of 4)

8. Once the desired pressure is reached, stop the ZEVAC equipment and the air compressor.
9. Record the final pressure readings in the intake section and discharge section of the pipe.

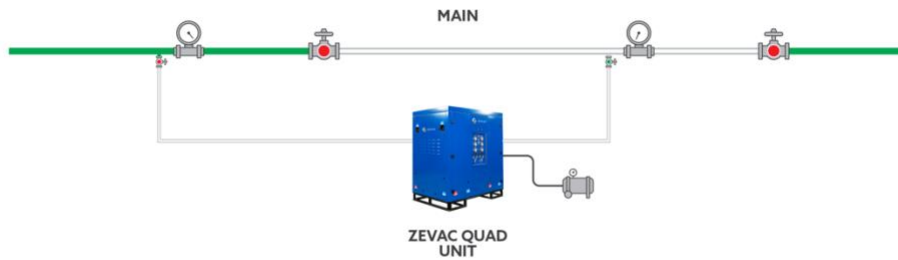

Figure 31: Diagram of main repair drawdown (Image 3 of 4)

10. Close tap valves and disconnect ZEVAC and air compressor equipment.
11. Repair main.



Figure 32: Diagram of main repair drawdown (Image 4 of 4)

Case Study: Main Repair

About the Project	
Who	Xcel Energy
What	Depressurization of 4.4 miles of 20" steel natural gas main
Why	Reduce emissions and shorten purge in busy area
Where	Aurora, CO
When	May 2022



ZEVAC was utilized to perform the drawdown of 4.4 miles of 20" high-pressure natural gas pipeline. Since this project was in the Denver metro area, with residential and commercial areas nearby, the use of ZEVAC was very attractive. Projects of this type commonly consist of thousands of feet of mainlines and services, ZEVAC can be used effectively to minimize commodity losses and the release of natural gas into the atmosphere.

This project, Parker 20" Fitting Replacement Blowdown, was the complete depressurization of 4.4 miles of 20" natural gas pipeline to perform a fitting replacement. Three ZEVAC Quad M models were used alongside two mobile air compressors. The drawdown process ran continuously for 31 hours with a starting line pressure of 267 psig and a final line pressure of 38 psig.

For this project, the drawdown of the line took longer than anticipated and the ZEVAC operation was stopped at 38 psig. The units were very effective at reducing emissions and provided valuable data for future ZEVAC projects and drawdown time estimations. At the conclusion of this project, 744,241.8 scf was not released into the atmosphere.



Figure 33: Pressure indicator before drawdown



Figure 34: Pressure indicator after drawdown

Although this project achieved success in reducing emissions, we fell short of our ultimate objective to complete the full drawdown within the original estimated timeframe of 26 hours. To prevent such setbacks in the future, it is imperative to prioritize the use of reliable equipment, particularly rental air compressors, and ensure they are properly maintained and set to meet the required specifications. By implementing these measures, we can effectively avoid similar errors and enhance our overall project efficiency.



Figure 35: ZEVAC equipment setup

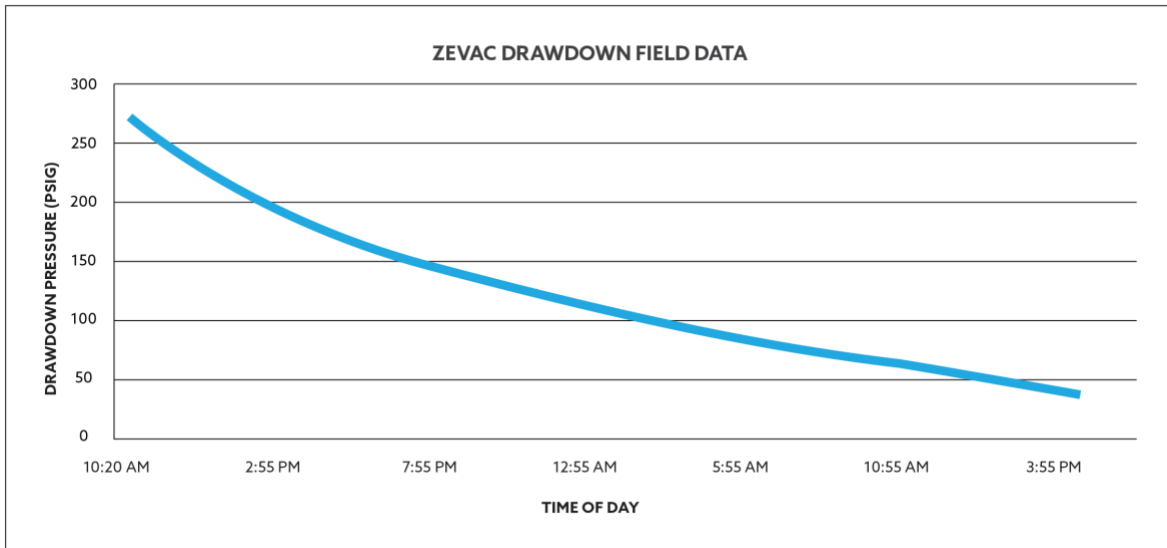

Figure 36: ZEVAC drawdown field data - Parker 20" fitting replacement blowdown

Results, Conclusions, and Lessons Learned

Overall, the use of ZEVAC for this project was effective. As seen below, 744,241.8 scf of methane was not vented into the atmosphere, the equivalent of 422.8 metric tons of CO₂. Both results show the deployment of ZEVAC was impactful in reducing emissions. Always consider the frequency of these actions. This report is from a single instance of a main repair and pipeline operators routinely perform pipeline main repairs that typically involve flaring or venting. By utilizing ZEVAC for future main replacements, significant decreases in methane emissions can be achieved.

The ZEVAC impact from the main repair:

423 Metric Tons CO2e Saved	744,242 SCF Natural Gas Not Vented	1,083,758 Miles Not Driven
	473,553 Pounds of Coal Not Burned	146 Tons of Waste Recycled Instead of Landfilled
	504 Acres of Forest Grown for One Year	6,990 Seedlings Grown for 10 Years

One valuable lesson we have learned from this project is the importance of ensuring the reliability and optimal performance of the equipment used in conjunction with ZEVAC. It became evident that the failure to meet the calculated drawdown time was directly attributed to equipment that did not perform up to its rated values.

Our overarching objective encompasses more than the mere pursuit of zero emissions in all our projects. In fact, it is the customary outcome of all our projects, barring any exceptional variables as previously stipulated. The attainment of zero emissions, facilitated by ZEVAC, stands not only as an attainable goal but as a routine achievement that is seamlessly integrated daily.